

20W TO-126 HIGH POWER RESISTORS

Features

- Non-Inductive, Small, 20 Watt high power resistor.
- TO-126 style package offering a very low thermal resistance of 5.9 C°/W.
- Complete thermal flow design available for easy implementation.
- Superior vibration durability.
- Small thin package for high density PCB installation.
- RoHS compliant.

Applications

- High frequency emitter resistors in switching power supplies.
- High precision CRT color video amplifiers.
- High frequency snubber and pulse handling circuits.
- VHF amplifiers.
- Pulse generator load resistors.

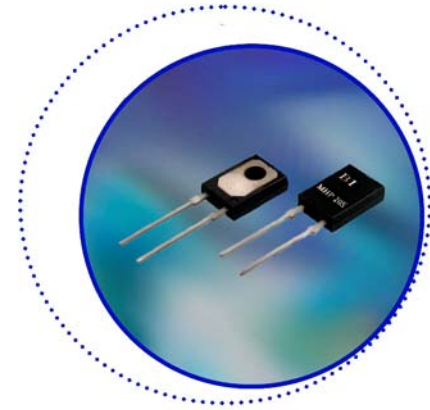

Specification

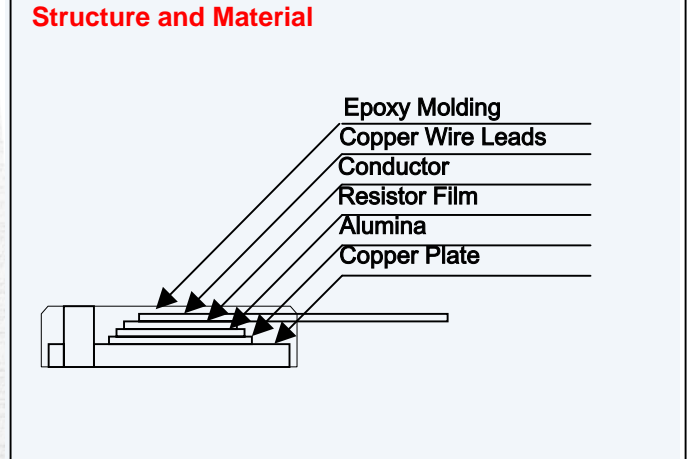
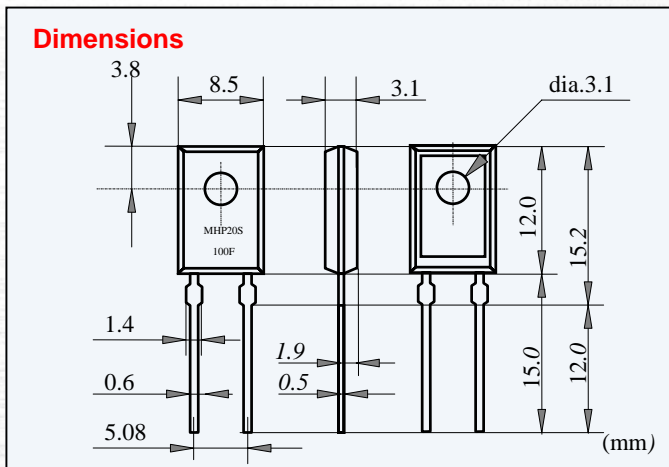

Items	Specification			Conditions
Power Rating	20 Watts			@ Tab Temp < 25°C
Power Rating	1 Watts			Free air.
Thermal Resistance	5.9°C/W			From hot spot to tab.
Resistance Range	0.01-0.09 Ω	0.1-9.1 Ω	10-220 Ω	Extended resistance range to 51KΩ avail.
Nominal Resistance Series	E6	E12	E24	Additional 2.0Ω and 5.0 Ω also avail.
TCR	250 ppm/°C	100 ppm/°C	50 ppm/°C	For -55 to +155°C
Tolerance	+/-5%	+/- 5% and 1%	+/- 1%	
Operation Temp. Range	-55 to +155 °C			
Dielectric Withstanding Voltage	2000 Volts DC			60 seconds. between terminals and flange
Load Life	ΔR +/- (1.0 % + 0.05 Ω)			25°C, 90 min. ON, 30 min. OFF, 1000 hours.
Humidity	ΔR +/- (1.0 % + 0.05 Ω)			60°C, 90-95% RH, DC 0.1W, 1000 hours.
Soldering Heat (Max)	ΔR +/- (1.0 % + 0.05 Ω)			250 +/- 5°C, 3 seconds,
Solderability	Min 95% coverage			230 +/- 5°C, 3 seconds.
Insulation Resistance	Over 1000 MΩ			Between terminals and metal back plate.
Vibration	ΔR +/- (0.25 % Ω)			

Specifications subject to change without notice

Notes:

1. Electrically isolated metal tab.
2. Recommend the use of thermal grease between metal tab and heat sink.
3. Thermal design should account for a thermal resistance between resistor and tab of 5.9°C/W and a maximum resistor temperature of 155°C.
4. Current rating: 25A maximum.
5. For the resistance range 220Ω to 51KΩ, the power rating is restricted to 10W.

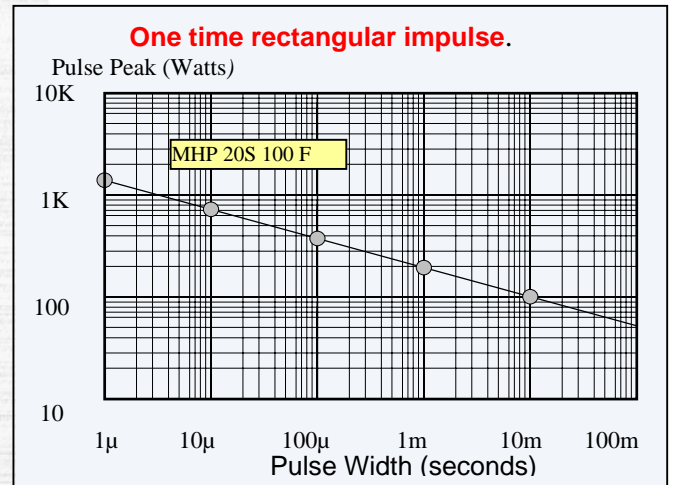
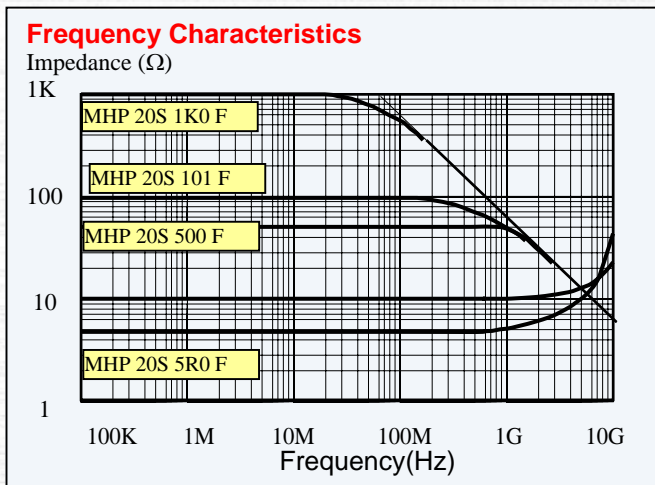
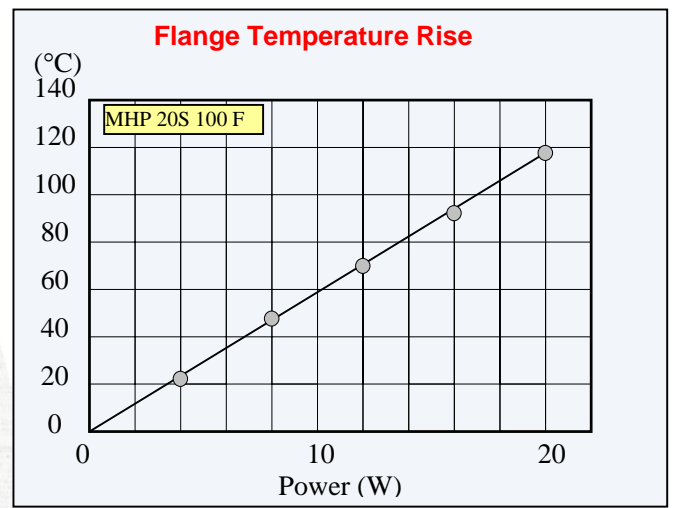
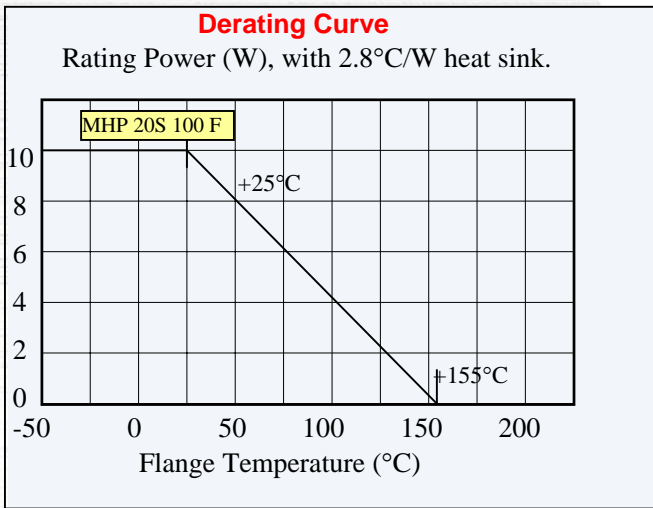

Ordering Information

